

Features

- Provides a “hit and hold” circuit for solenoid valves by stepping down DC voltage
- Reduces Electric Power Consumption while in the “hold” setting
- Permits Faster Response Time
- Allows Higher Valve Flow and Pressure
- Turns valve off immediately when power is cut to the circuit
- Terminal Pins permit easy installation
- Can be mounted directly to 075 and 100 series solenoid valves

Specifications

Series	COOLCUBE-R	COOLCUBE-50R
Time from “hit” to “hold” voltage	100 ms	100 ms
Maximum input voltage	36 VDC	36 VDC
“Hold” voltage with 36 VDC input	12 VDC	18 VDC
“Hold” voltage with 24 VDC input	8 VDC	12 VDC
“Hold” voltage with 12 VDC input	4 VDC	6 VDC
Input voltage step down to:	1/3	1/2
Power consumption reduction to:	1/9	1/4

Note: The COOLCUBE-50R can be used with all Bio-Chem Valve solenoid products. The COOLCUBE-R can be used with all Bio-Chem Valve solenoid products except 038, 039, 040 series, and “quiet” pinch valve products.

Dimensions

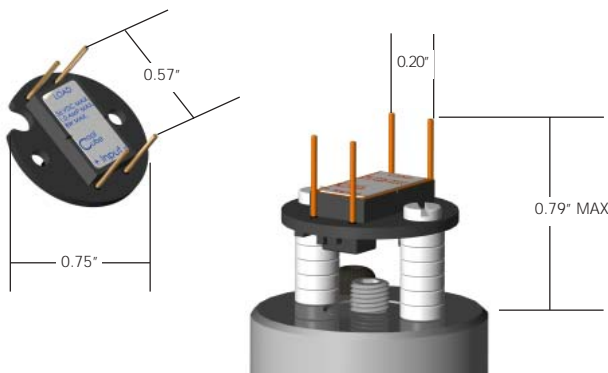

“Step-down” Function

The compact CoolCube™ solenoid control module products provide an easy way to achieve a “hit and hold” circuit independent of the rated voltage. When a CoolCube™ is connected between a solenoid valve and a power supply, it delivers a “step-down” function. It accepts a range of inputs from 12 to 36 VDC and passes the input on to energize the solenoid valve with full power for 100 ms. After 100 ms, the CoolCube™ drops the voltage and current to a level sufficient to hold the solenoid in the energized position. The benefits are less power consumption and lower heat generation. The CoolCube™ can remain under power indefinitely without being damaged. When the power to the CoolCube™ is cut, the valve is turned off immediately, as though the CoolCube™ was not in the system.

Overdrive Function

The CoolCube™ permits placing an overdrive voltage on a solenoid valve. This means that a solenoid valve rated for 12 VDC or 24 VDC can be energized with a voltage of 24 VDC or 36VDC respectively. Since the CoolCube™ automatically drops the voltage after 100 ms, the solenoid will not be impaired in any way. The advantages are:

- **Faster Response Time** - The valve response time can be decreased by up to 60%.
- **Increased Pressure Rating** - The operating pressure rating can be dramatically increased*.
- **Larger Pinch Valve Tubing** - The valve stroke can be increased, allowing the use of larger tubing with the same basic pinch valve design*.

Please contact a Bio-Chem Valve application specialist for further information on these possibilities.

* Other valve customization by the factory may be required depending on the specific application.

Installation Instructions

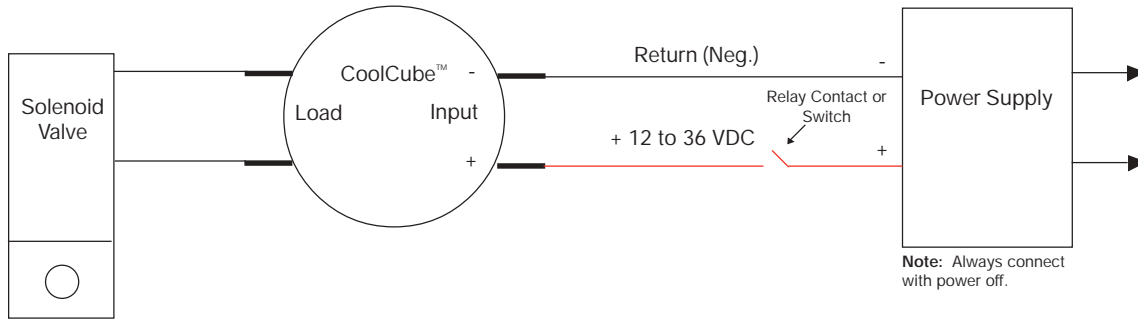

1. Using an AMP*, Molex or similar connectors, connect the CoolCube™ to the DC power supply.

Caution: Note the polarity indicated on the input side of the CoolCube™. If power is reversed, the unit will not function correctly.

2. Using an AMP*, Molex or similar connectors, connect the valve lead wires to the CoolCube™.
3. Turn on the power supply. Caution: do not turn on the power supply before the CoolCube™ is connected to the valve.

* Connectors are available with 15" of 26 AWG Teflon coated wire as P/N LWA-2 for the "input pins" and the "load pins".

Ordering Information

Part Number	Can be used with:
COOLCUBE-50R	All Bio-Chem Valve solenoid valve products.
COOLCUBE-R	All Bio-Chem Valve solenoid valve products except 038, 039, 040 series and "quiet" pinch valves

Trademarks:

CoolCube™ is a trademark of Bio-Chem Valve Inc.